

Item	Description	Qty
A	Support Bracket	1
B	Mounting Bracket	1
C	ECU Mount	1
D	Motor Mount	1
E	Lower Shaft	1
F	Upper Shaft	1

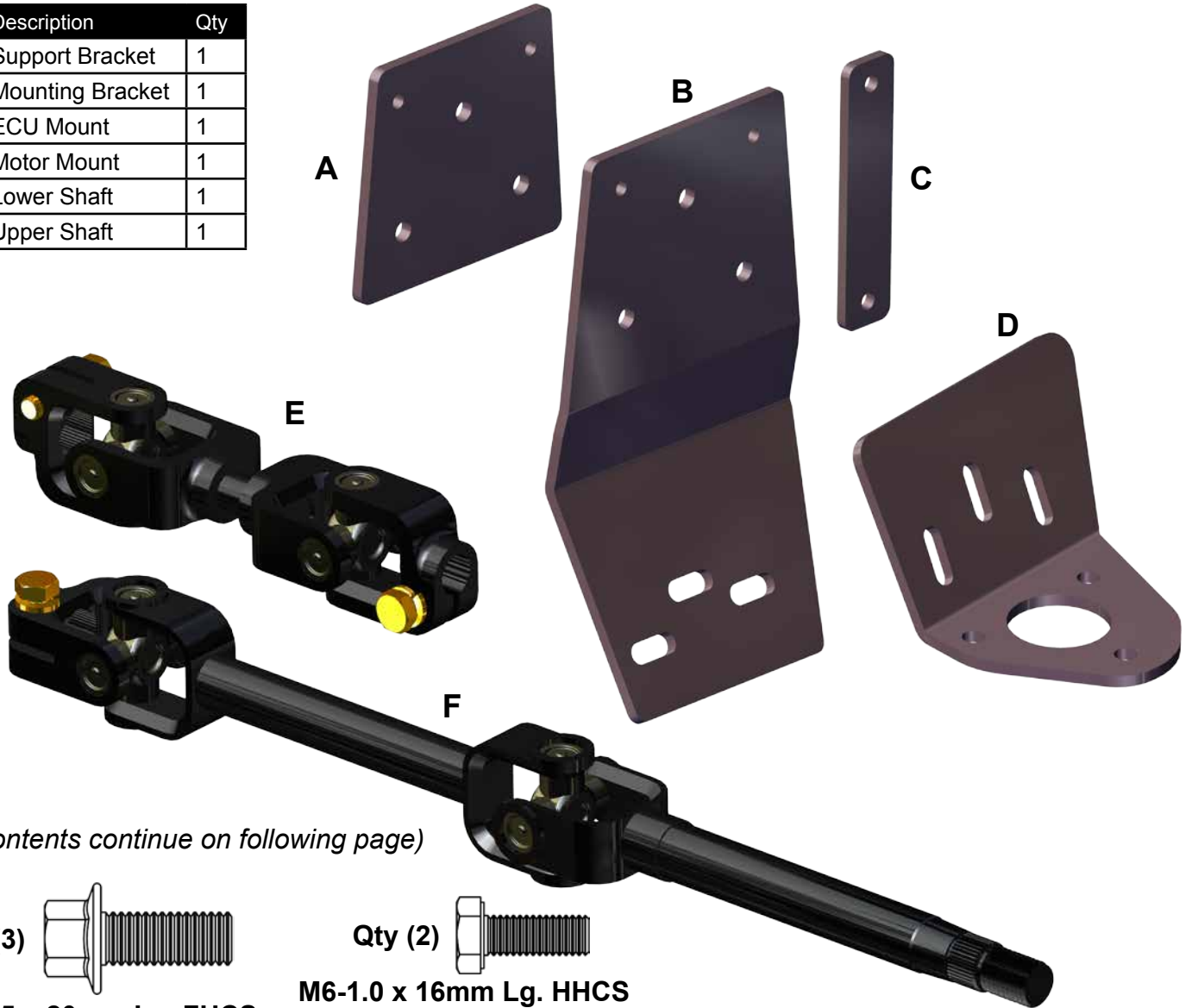

(Kit contents continue on following page)

Qty (3)

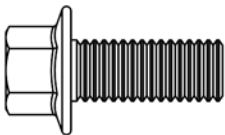

M8-1.25 x 20mm Lg. FHCS

Qty (2)

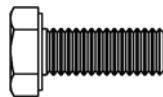

M6-1.0 x 16mm Lg. HHCS
-includes washers (not shown)

Read instructions and view illustrations before beginning.

Need help with your installation?



sales@superatv.com



www.superatv.com



1-812-574-7777



8:00am - 9:00pm EST M-Th
8:00am - 7:00pm EST Friday
9:00am - 2:00pm EST Saturday

*Thank You
For Choosing*

SUPERATV.COM

Liability Statement

SuperATV's products are designed to best fit users ATV/UTV under stock conditions. Adding, modifying, or fabricating any factory, or aftermarket, parts will void any warranty provided by SuperATV and is not recommended. SuperATV's products could interfere with other aftermarket accessories. If user has aftermarket products on machine, contact SuperATV to verify that they will work together.

Although SuperATV has thousands of satisfied customers, user should be aware that installing lift kits, long travel, or suspension kits, tires, etc will change the ride of machine and may increase maintenance and part wear. Operating any off-road machine while, or after, consuming alcohol and/or drugs increases risk of bodily harm or death. No warranty or representation is made as to this product's ability to protect user from severe injury or death. SuperATV urges operators and occupants to wear a helmet and appropriate riding gear at all times.

By purchasing and installing SuperATV products, user agrees that should damages occur, SuperATV will not be held responsible for loss of time, use, labor fees, replacement parts, or freight charges. SuperATV, nor any 3rd party, will not be held responsible for any direct, indirect, incidental, special, or consequential damages that result from any product purchased from SuperATV. The total liability of seller to user for all damages, losses, and causes of action, if any, shall not exceed the total purchase price paid for the product that gave rise to the claim.

SuperATV will warranty only parts provided by SuperATV. Any damage or problems with OEM housings, bearings, seals, or other manufacturers products will not be covered by SuperATV. SuperATV parts and products are not warranted if item was not installed properly, misused, or modified.

Item	Description	Qty
G	ECU	1
H	Motor	1
J	Wire Harness	1

(Kit contents continued)

Qty (6)  M8-1.25 Nylock Nut

Qty (2)  M5-.80 Nylock Nut

Qty (2)  M6-1.0 x 60mm Lg. FHCS

Qty (6)  M8-1.25 x 25mm Lg. FHCS

Qty (2)  M5-.80 x 20mm Lg. FHCS

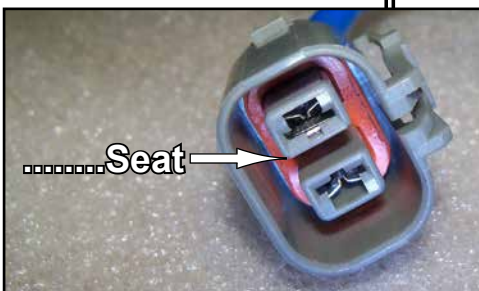
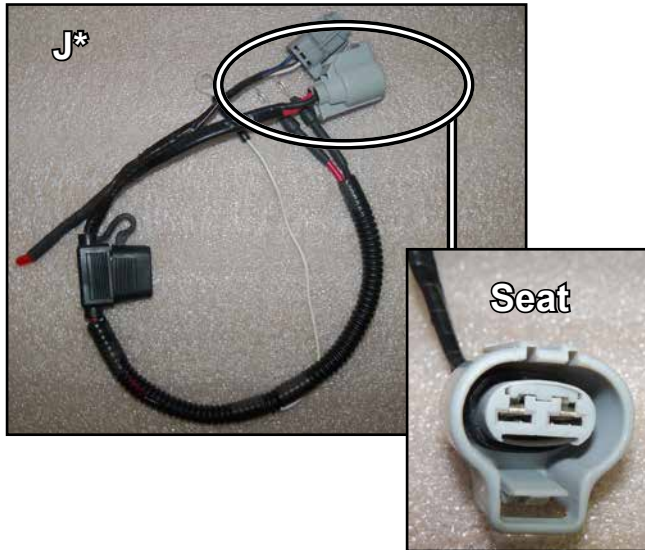
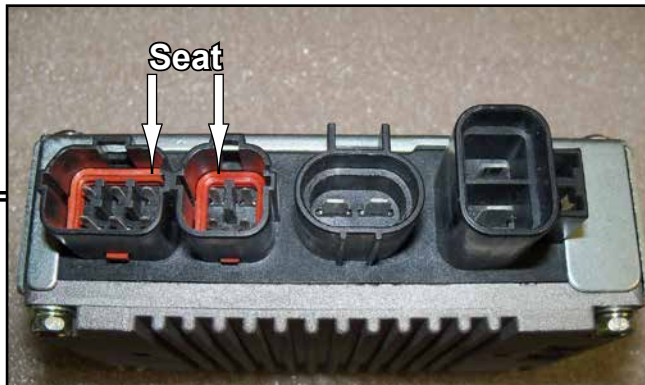

***Connections**

- Before installing, ensure that all Gaskets in electrical connections are properly seated.
- If Gaskets are not seated use a Flathead Screwdriver to seat.

Removal: Keep all components removed from machine.

1. Remove Tilt Adjust hardware and Ignition. See Fig. 1.
2. Remove hardware and Plastic Rivets securing Floor Panels to Floor and Rocker Panels; remove Floor Panels. See Figs. 2 - 2a.
3. Remove Plastic Rivets securing Front Box and Upper Cab Panel. See Fig. 3.
4. Remove Front Roll Cage Hardware; remove Front Roll Cage. See Figs. 4 - 4a.
5. Remove Front Box and Upper Cab Panel.
6. Remove Steering Wheel and Pivot Tube. See Figs. 5 - 5a.
7. Remove Steering Shaft from Rack and Pinion. See Figs. 6 - 6a.

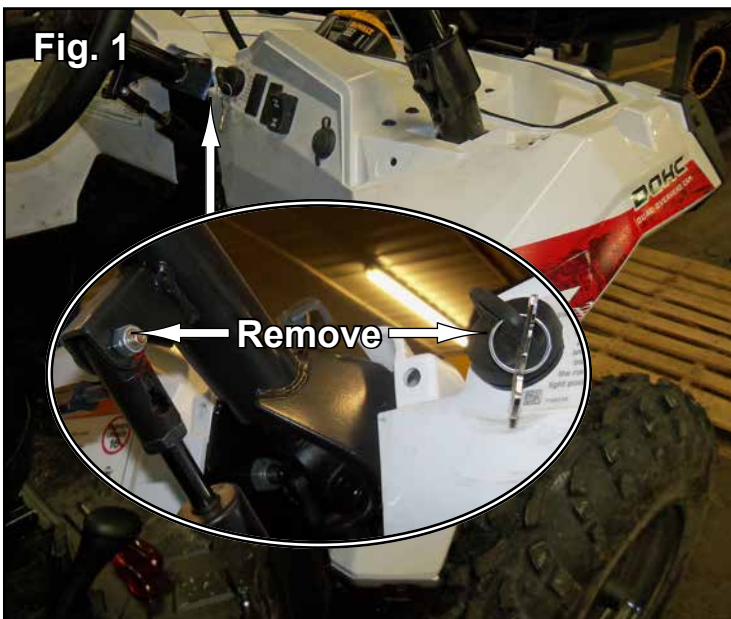

(removal illustrations on following pages)

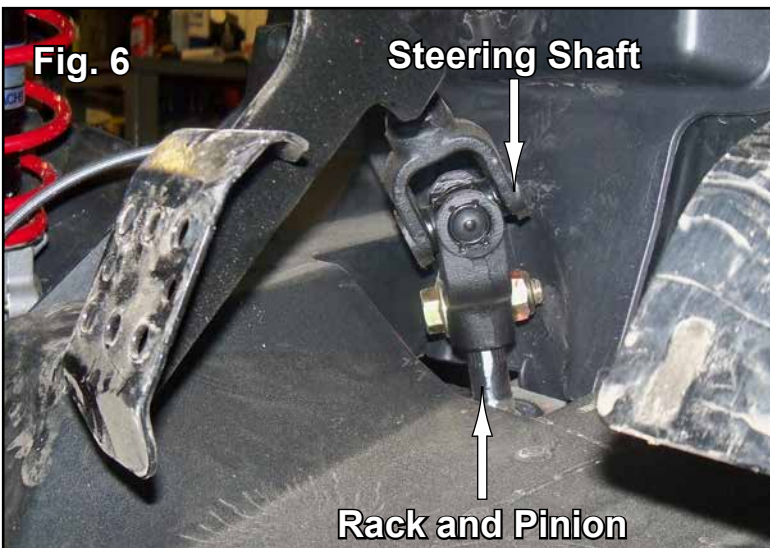
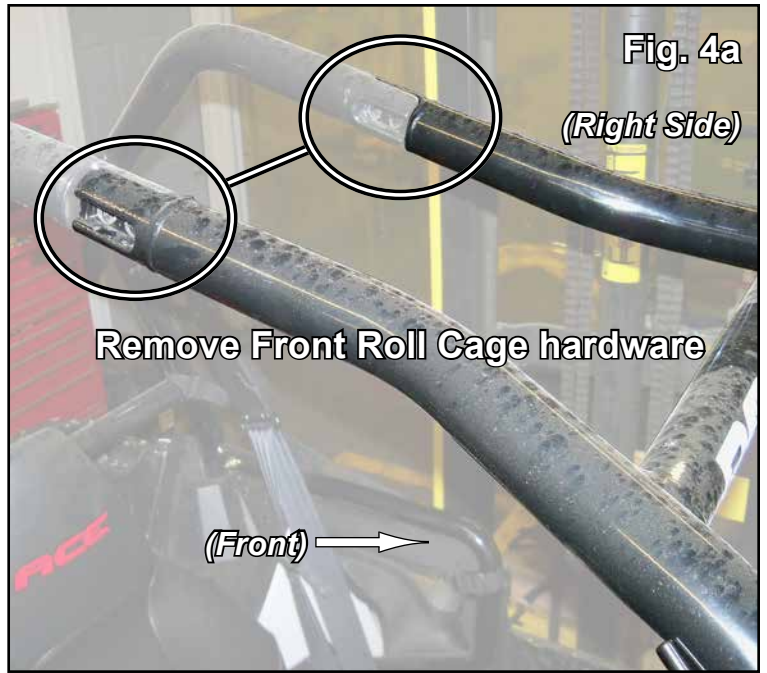
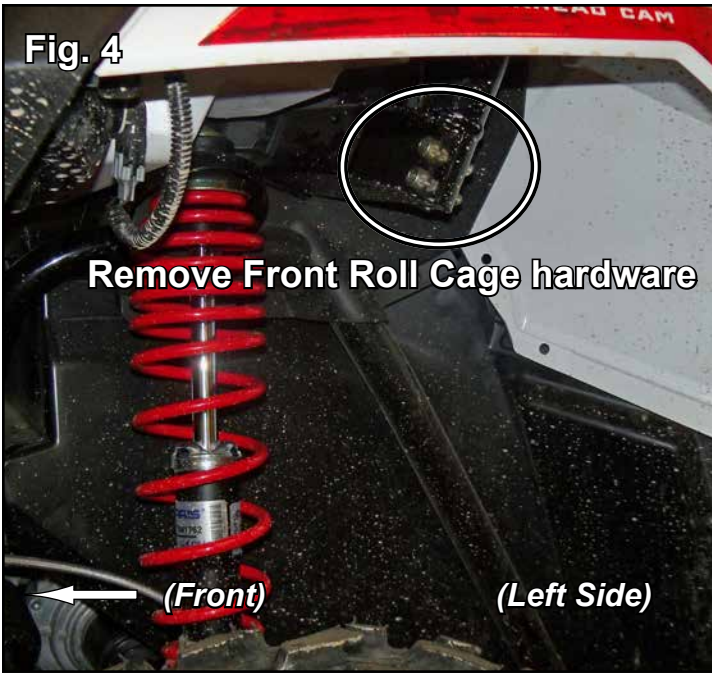

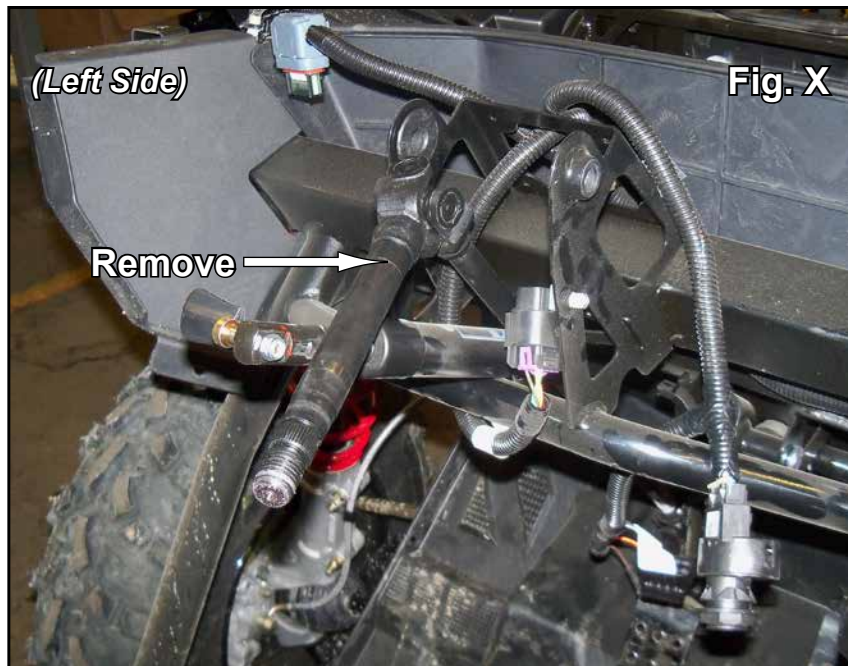

Installation: Do not tighten hardware unless noted.

1. Install Lower Shaft (E) to Rack and Pinion with provided hardware. See Fig. 1.
2. Install Motor (H) onto Lower Shaft (D) with provided hardware. See Motor Shafts Detail and Fig. 1.
3. Install Motor Mount (D) to Motor (H) with M8-1.25 x 20mm Lg. FHCS. See Fig. 2.
4. Install Support Bracket (A) and Mounting Bracket (B) to Steering Frame with M5-.80 x 20mm Lg. FHCS, M5-80 Nylock Nuts, M8-1.25 x 25mm Lg. FHCS, and M8-1.25 Nylock Nuts. See Figs. 3 - 3b.
5. Join Motor Mount (D) and Mounting Bracket (B) with M8-1.25 x 25mm Lg. FHCS and M8-1.25 Nylock Nuts. See Fig. 4.
6. Install Upper Shaft (F) to Motor (H) with provided hardware. See Fig. 4a.
7. Install ECU (G) and ECU Mount (C) to Frame with M6-1.0 x 60mm Lg. FHCS. See Figs. 5 - 5a.
 - Plug in Wire Harness (J) and plugs from Motor (H). Ensure wires have clearance between *all* components. Secure as needed.
 - Proceed to "Wire Details", pages 10 - 11.
8. Reverse steps taken during "Removal" and reinstall necessary components with stock hardware.
9. Tighten all hardware completely.

NOTE: With Steering Wheel tilted to lowest setting, slight resistance may be felt at times. If possible do not use lowest setting.

(installation illustrations on following pages)

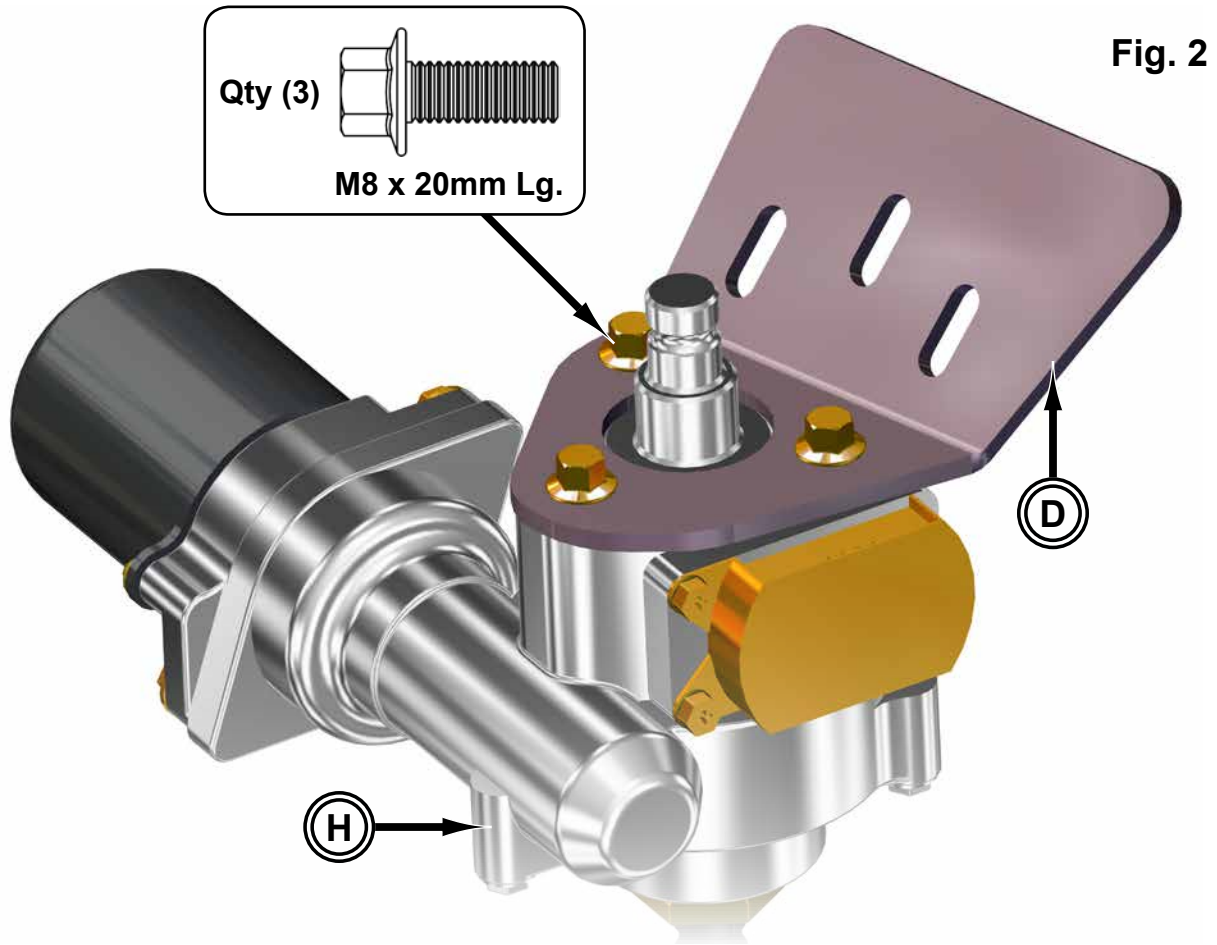
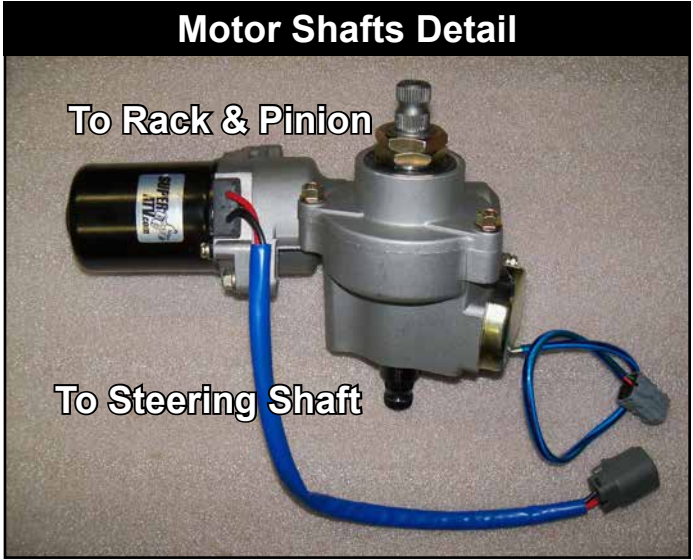
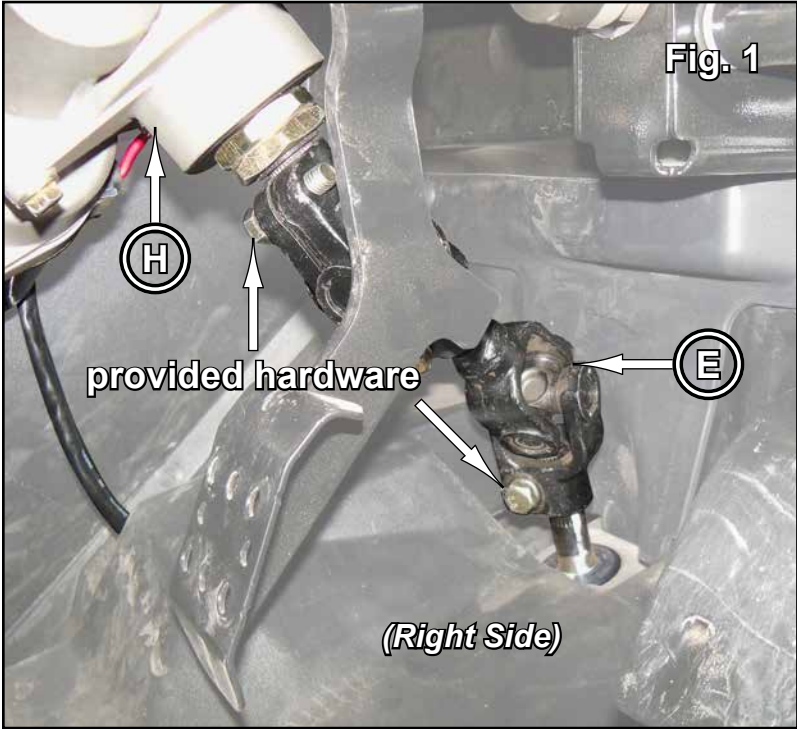

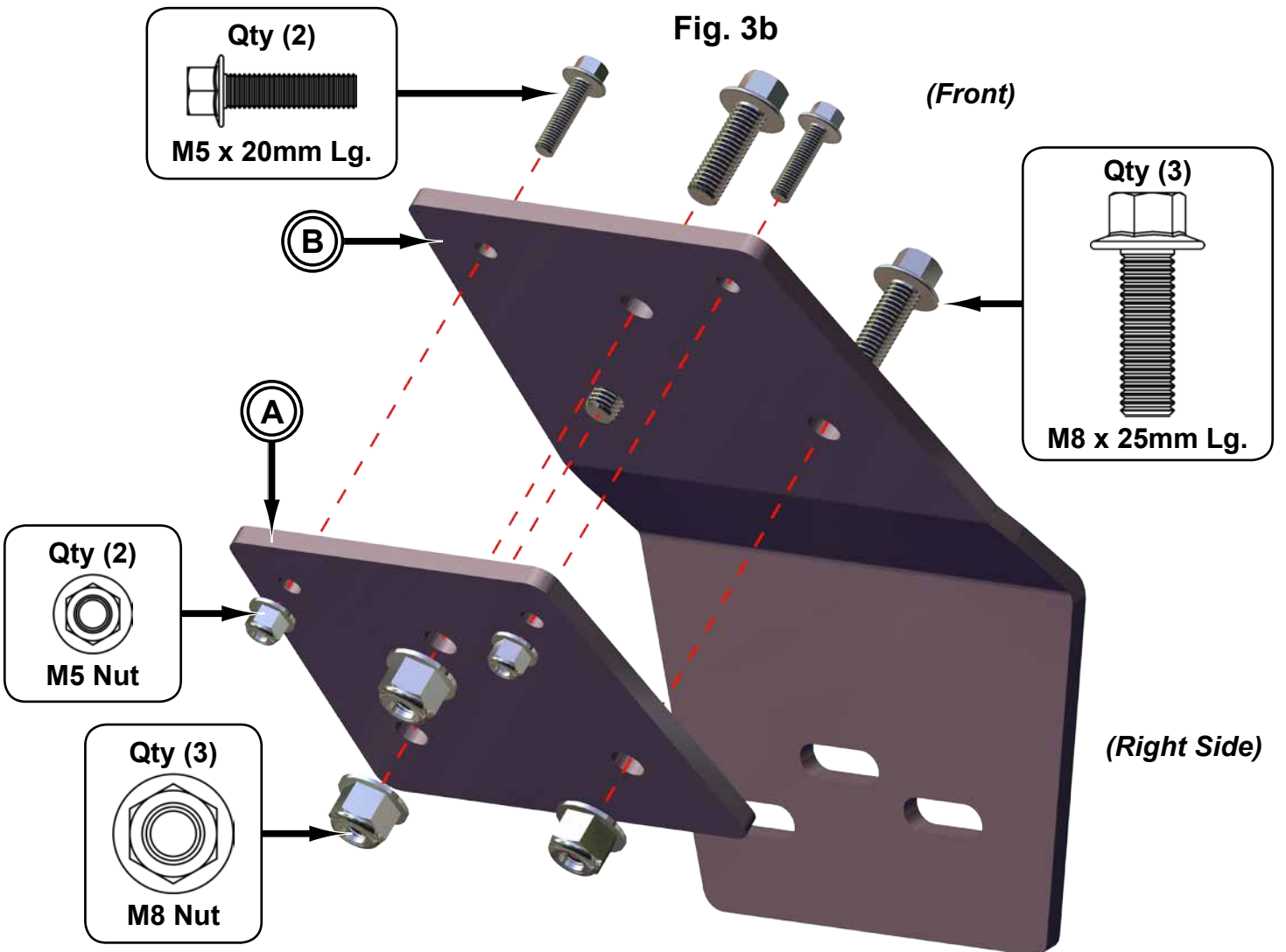
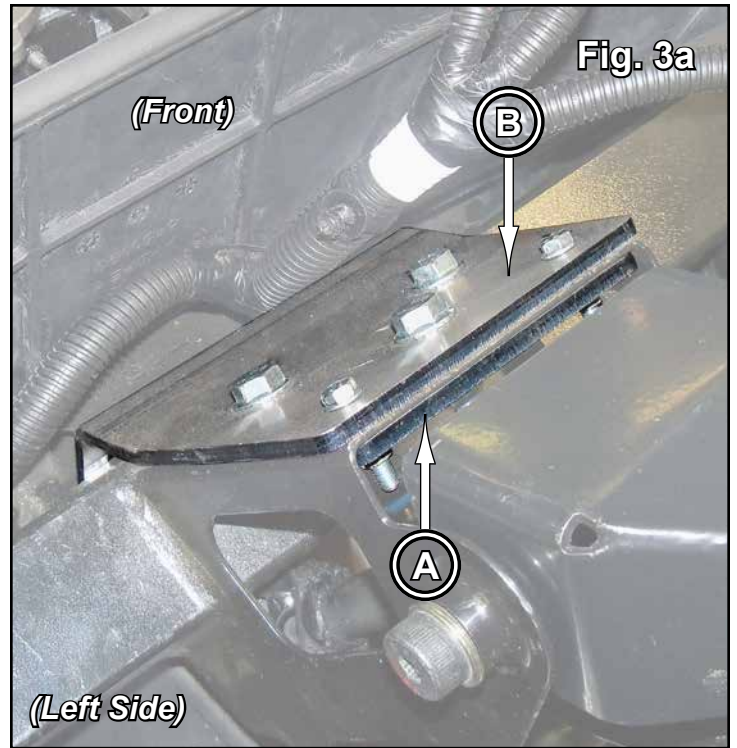
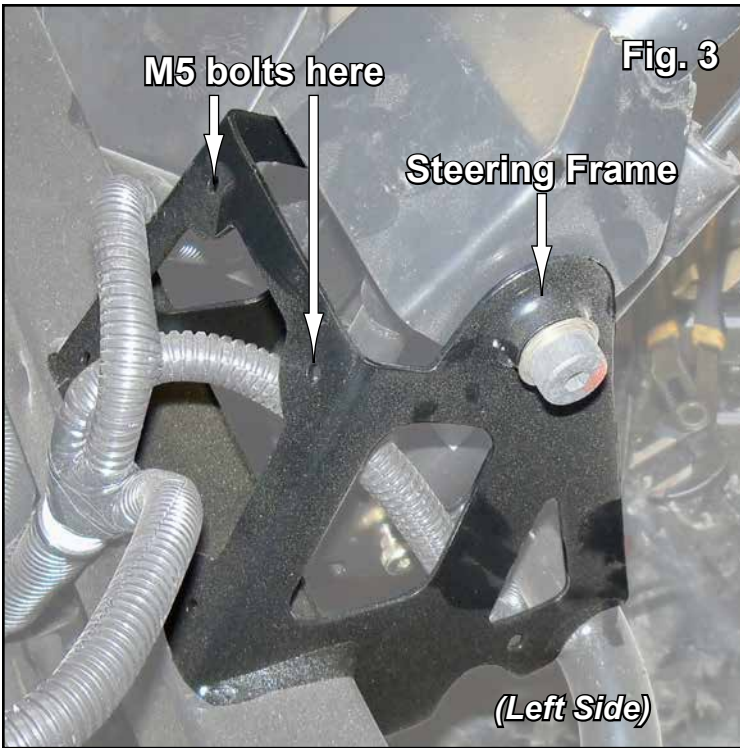
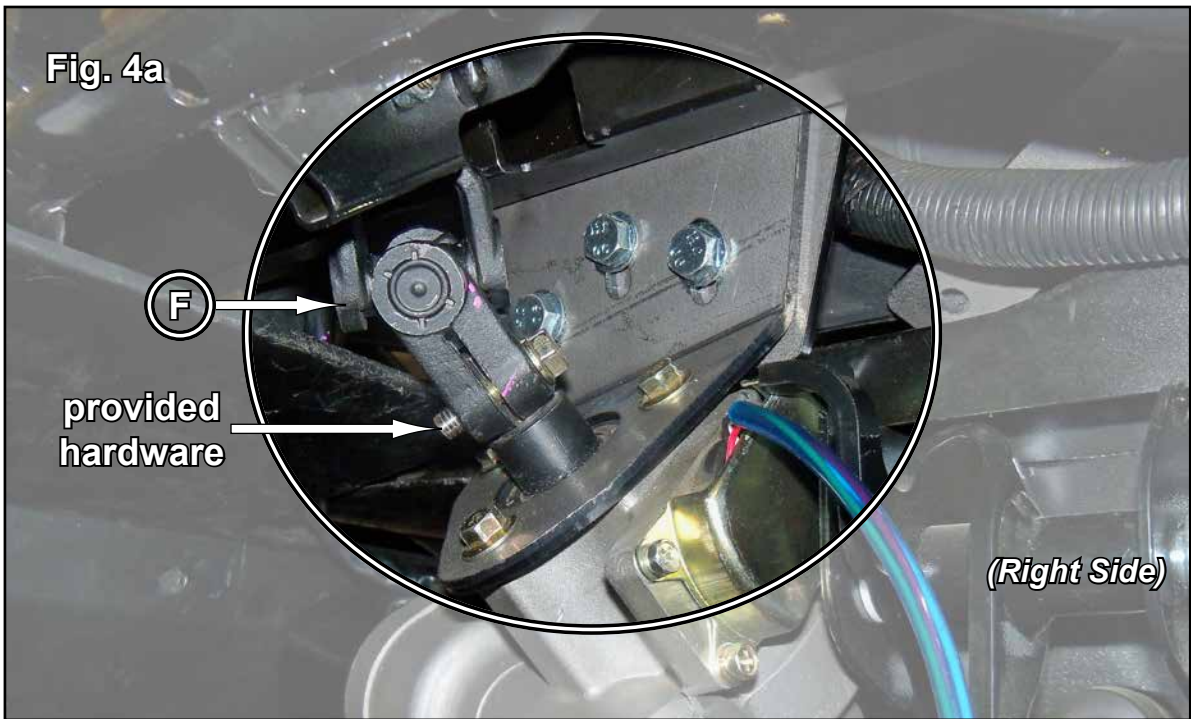
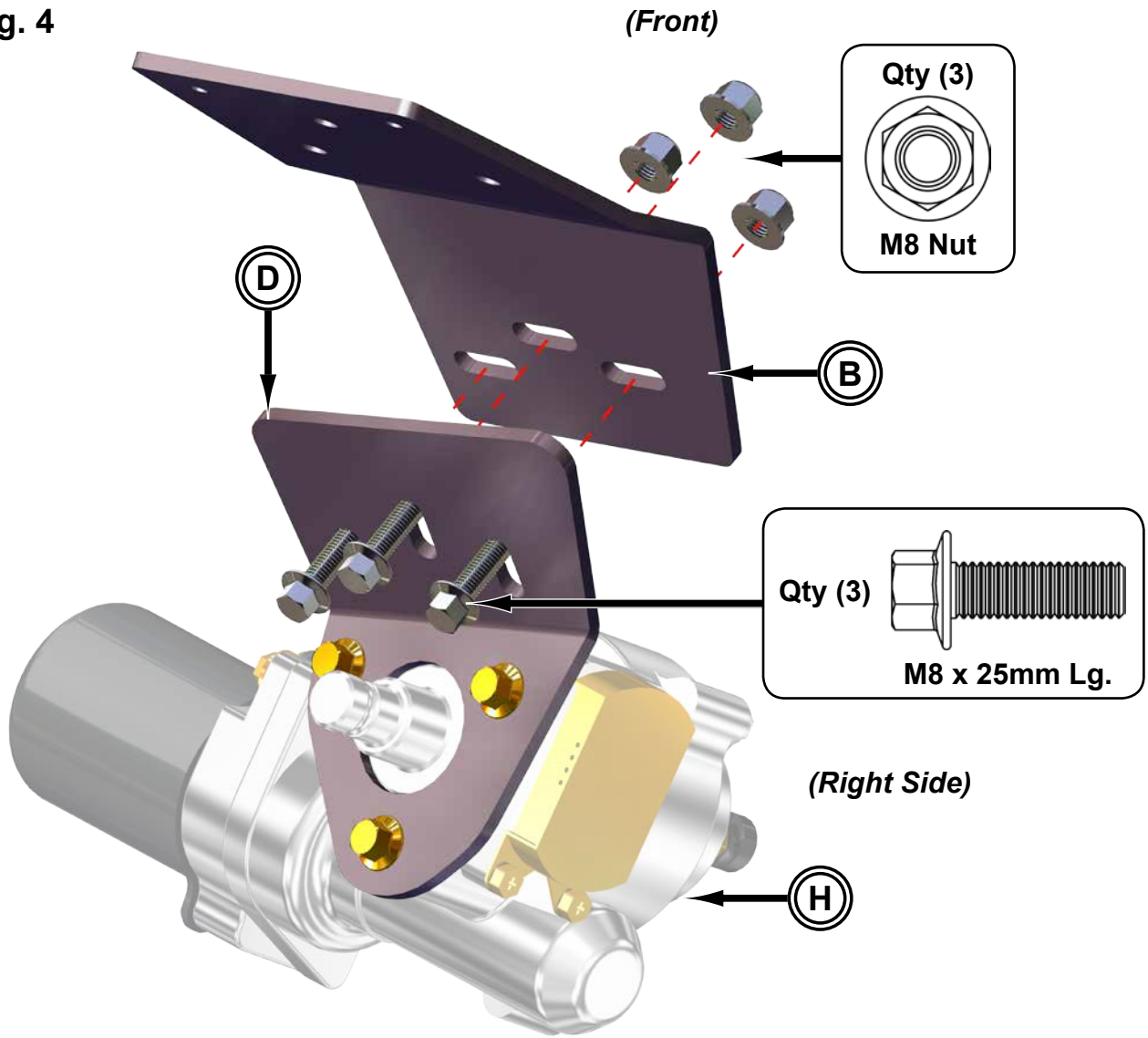
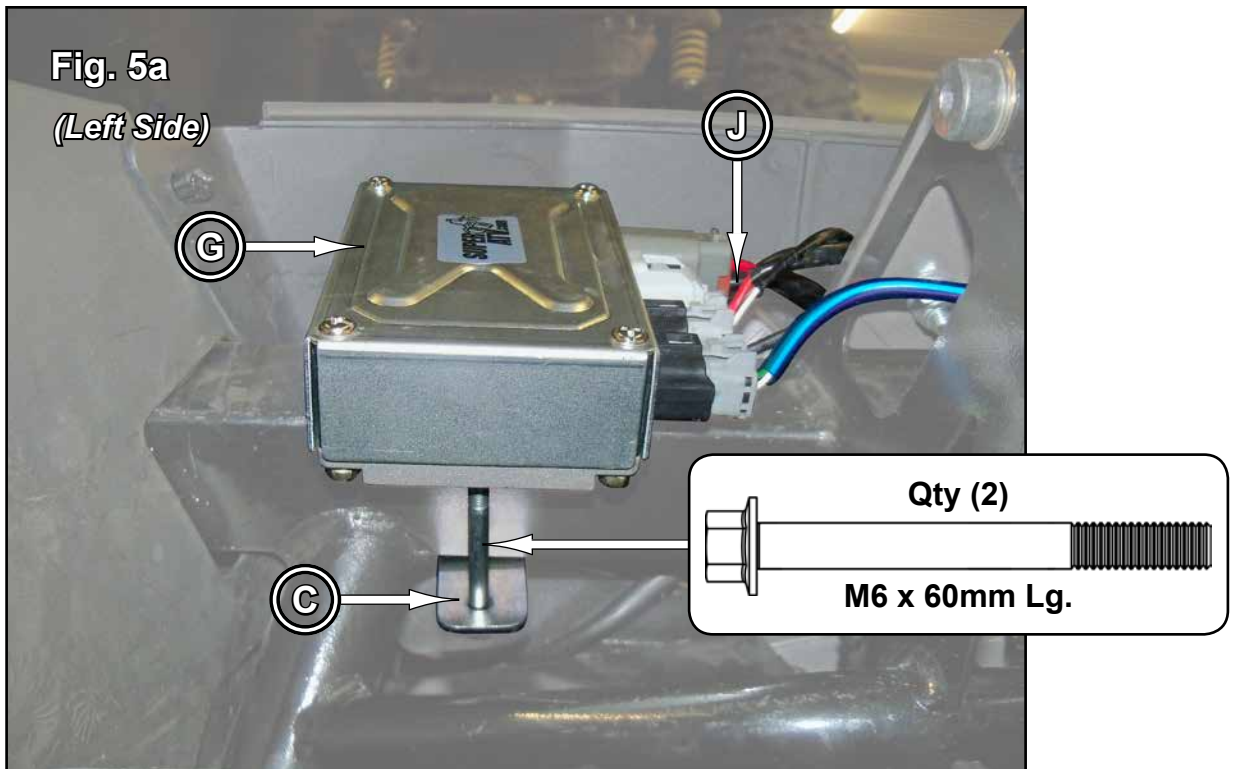
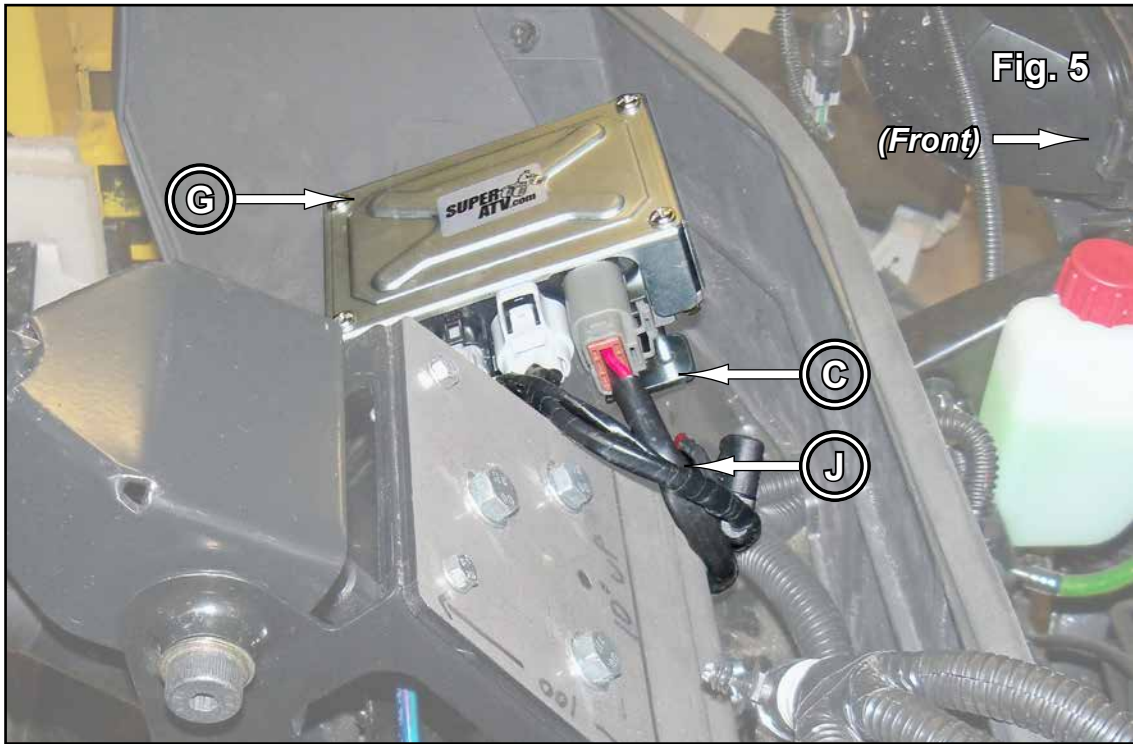
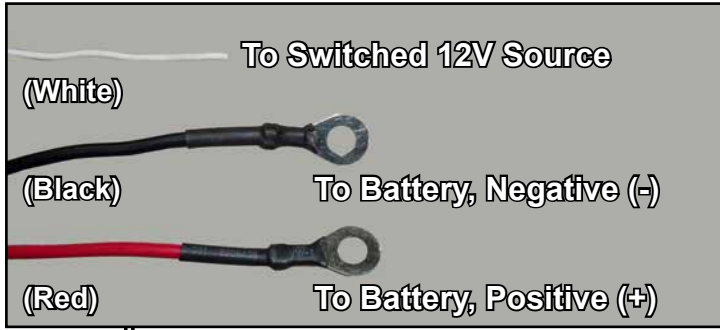

Fig. 4





Wiring Details



Plug	Function
A	Torque Sensor
B	Switched 12V Source
C	Power
D	Motor

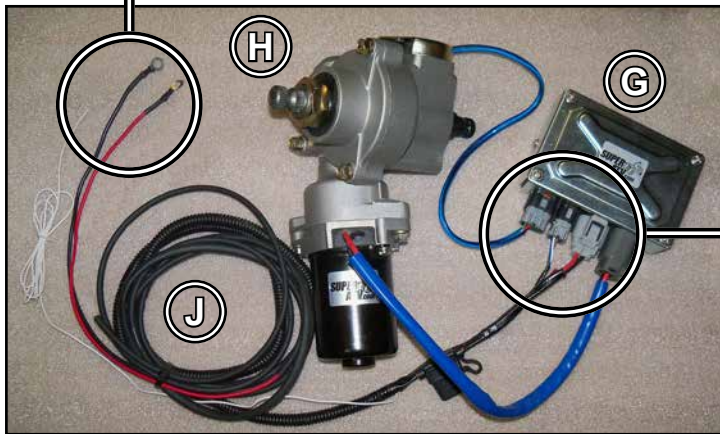

Wiring Details continued

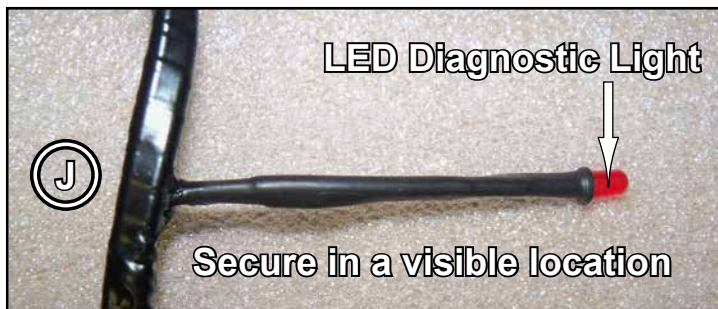
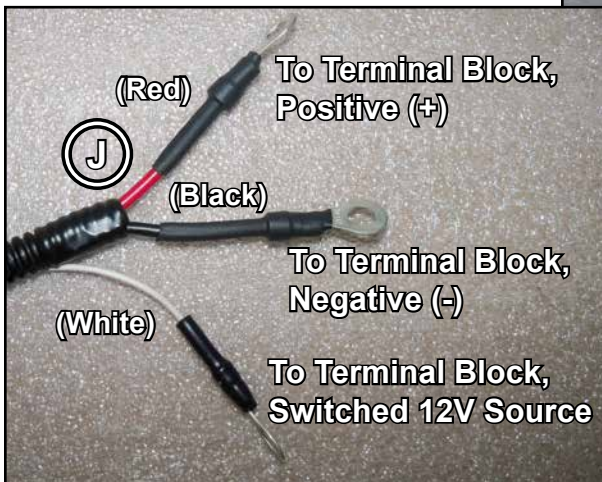
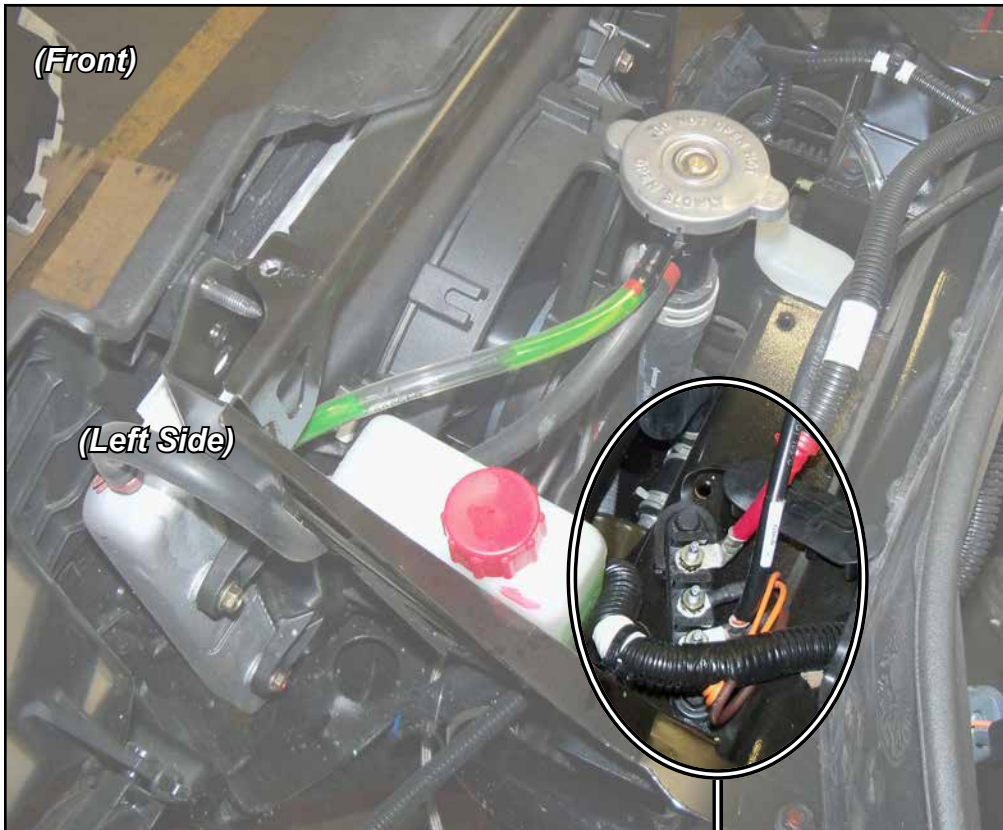

When activated, LED Diagnostic Light will flash once for about 1 second before turning off indicating proper function. Should different patterns occur, contact SuperATV.